

Pump Your Needs.

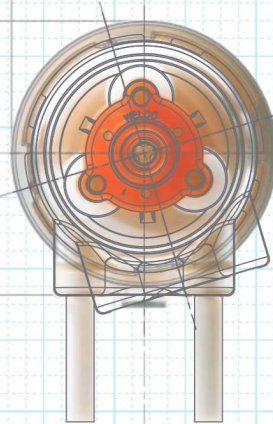









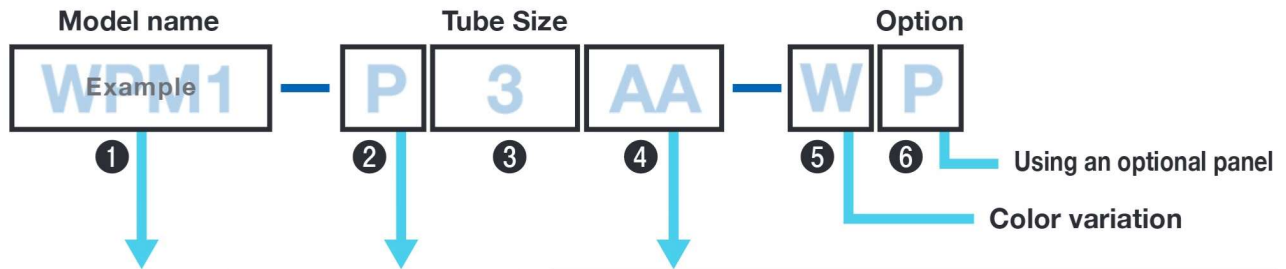
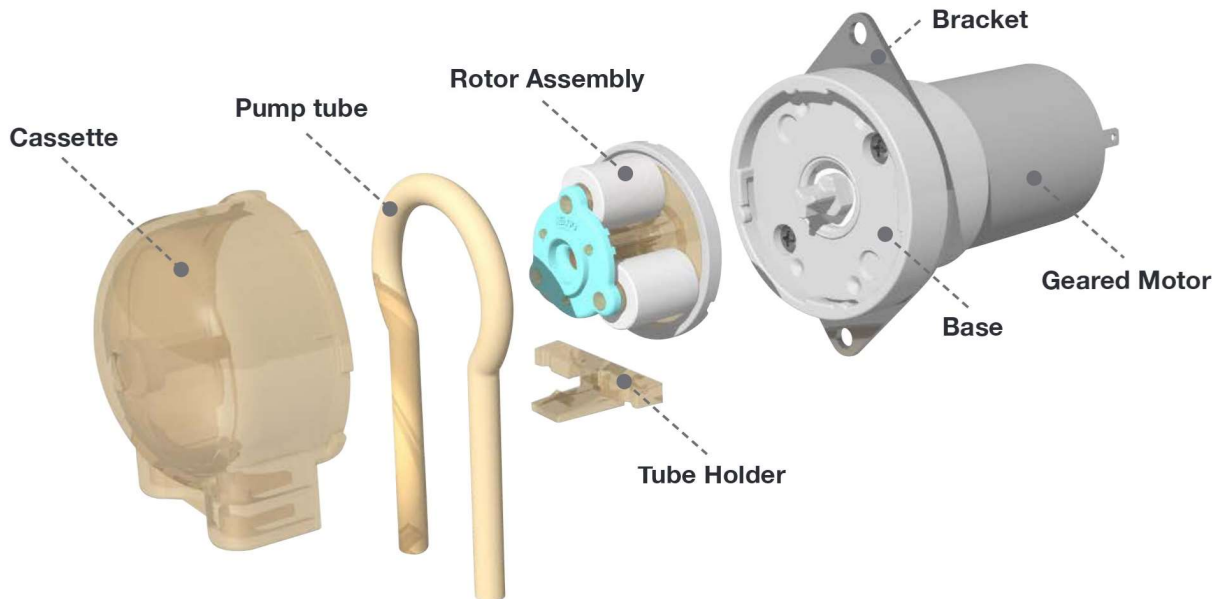



**WELCO's easy ordering system
can match the best product to the customer's needs**

WPM PERISTALTIC PUMP SELECTION GUIDE

A specification of WELCO Peristaltic pumps can be determined by many combination of parts.

Please select each parts according to your requirement.



Series name	Pump tube type	Geared motor type			
WPM1 	P PHARMED BPT  Inner diameter 1mm/1.6mm(1/16") /2mm/2.5mm/3mm	AA/BA 24/12VDC Brush motor (1/14 Gear ratio) 	AB/BB 24/12VDC Brush motor (1/196 Gear ratio) 	CA 12VDC Compact Brush motor (1/14 Gear ratio) 	
	NF TYGON A-60-F (Norprene A-60-F)  Inner diameter 1mm/1.6mm(1/16") /2mm/2.5mm/3mm				
WPM2 	S TYGON 3355  Inner diameter 1mm/2mm/3mm	EA Stepper motor 	DB/FB 12/24VDC Brushless motor 		
	F Fluran F-5500-A  Inner diameter 1mm/1.6mm(1/16") /2mm/3mm				
	W W TUBE  Inner diameter 1mm/2mm/3mm				

1 Pump Model

WPM1 - [] [] [] - [] []



Super Engineering Plastics

Super engineering plastic, having excellent corrosion resistance, are used for the main tube parts and enable the pumps to be used with strong acids, strong alkalis, and chemical solutions that erode general-purpose plastic. The heat resistance is also excellent, use in various environments can be supported.

Fluid temperature	5°C to 50°C
Material (Pump parts)	PSU (Cassette/Rotor/Base) , POM (Roller,etc)
Autoclave	Not Available



Compatible with autoclave sterilization (WPM2 model)

All parts of the WPM2 pump cassette are made of super engineering plastic that has excellent heat resistance. Autoclave sterilization can now be performed on industrial-use compact-size peristaltic pumps. Pump operation supports liquid solution temperatures of up to 80°C.

Fluid temperature	5°C to 80°C
Material (Pump parts)	PSU (All parts)
Autoclave	Autoclave condition: 0.1MPa, 121°C, 20min Only the Pump parts.

Note:





Autoclave sterilization is assumed to be performed under the conditions of 0.1 MPa (121°C) for 20 minutes.

Number of autoclave is supposed less than 30 times.(except pump tube)

If the actual conditions will exceed these values, be sure to perform a confirmatory evaluation. Even when using tubing that can be autoclaved, performing the autoclave sterilization process while the tubing is fitted to the pump may cause the flow rate to change. If this is a concern, **remove the tubing and sterilize.**

2 Pump tube type: Material (Selectable according to fluid type)

WPM1 - P 3 [] [] - [] []

Tube type	Product Description	Regulatory compliance/meets
PHARMED BPT P 	*Great resistant to general chemicals, acid, alkali and oxidizing agents *Compatible with virtually all commercial cleaners and sanitizers *Lasts up to 30 times longer than silicone tubes.	USP Class VI
TYGON A-60-F (Norprene A-60-F) NF 	*Food process tube for critical processing applications in the food, dairy and cosmetic industries. *Compatible with virtually all commercial cleaners and sanitizers *Great resistant to general chemicals, acid, alkali and oxidizing agents	FDA 21 CFR Part 177.2600 NSF 51 3-A
TYGON 3355 S 	*High-performance and platinum-cured silicone tube *Ultra-smooth inner bore reduces potential for particle entrapment *Excellent fluid flow characteristics.	FDA 21 CFR Part 177.2600 USP Class VI
Fluran F-5500-A F 	*A proprietary fluorelastomer tube *Excellent resistance to corrosive chemicals, oils, fuels and solvents *Ozone and UV Light resistant	-
W TUBE W 	*Dual-wall tube which has excellent resistant to chemicals, acid, alkali. *Inner layer: Polyolefin Outer layer: Thermoplastic Elastomers	-

Note: TYGON, Pharmed and Fluran are manufactured by Saint-Gobain Group.

3 Pump tube type: Tube size (Selectable according to the tube material)

Model name	1	1.6	2	2.5	3
Inner diameter	1mm	1.6mm (1/16")	2mm	2.5mm	3mm
Outside diameter	3mm	3.2mm (1/8")	4mm	4.5mm	5mm
Available tube material	P / NF / S / F / W	P / NF / F	P / NF / S / F / W	P / NF	P / NF / S / F / W

4 Geared motor types

WPM1 - P 3 AA - [] []
↑



DC Brush Motor & Gear

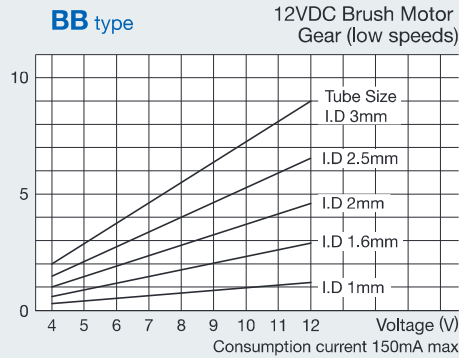
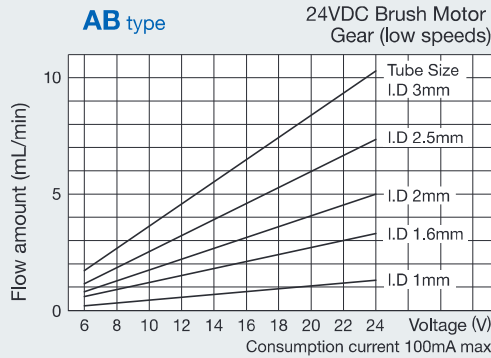
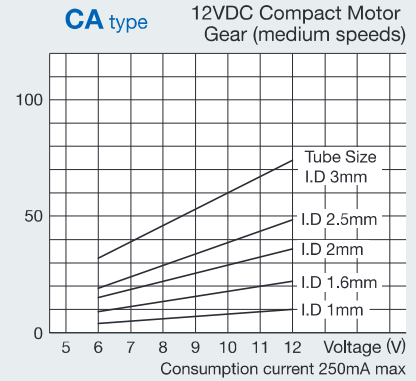
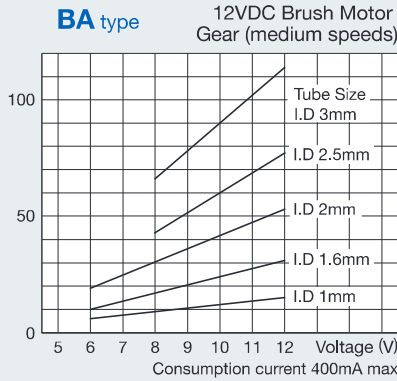
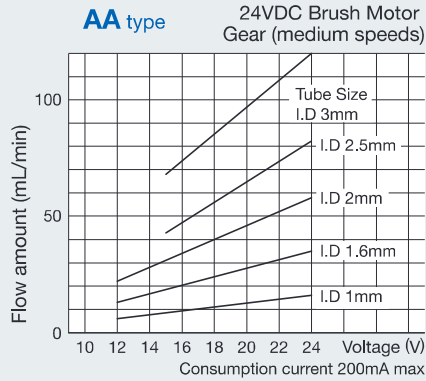

Caution:

- The current consumption indicated is the value during normal operation. When rotation begins, an inrush current of approximately 3 times this amount is generated.
- To determine the flow rate, the pump was installed at a height of 1.5mm, a hose having the same inside diameter as the pump tube was used, and the flow rate of distilled water was measured with a flow meter. The values indicated are for short-term operation and are not guaranteed for long-term operation. The flow rate has a tendency to increase until the tube becomes acclimated and different lots may have different flow rates within the specified tolerance. When the inside diameter of the hose is smaller than the inside diameter of the pump tube, the flow rate may decrease. Also, the rotating speed of the DC motor will vary depending on the load conditions and fluctuations in motor temperature. During the design stage, be sure to select a motor with ample headroom.
- Short circuit between terminals may occur due to end of motor life or short circuit between commutator slits by specific operating environment and condition. In order to prevent circuit burnout, please take protective measures such as using fuses.
- The lowest operation voltage may vary depending on the tube type, tube size, ambient temperature, etc. Please contact your sales representative to get help when you operate by lower voltage.

Specification

Geared motor model	AA/BA/AB/BB type	CA type
Max. Discharge pressure *1	90KPa (Pharmed BPT)	
Max. Suction pressure *1	-90KPa (Pharmed BPT)	
Duty Cycle	50%	
Motor operating temperature	Less than 60°C	
Operating noise *2	Approx. 52dB (JIS B 8310:1985)	
Geared motor endurance *3	More than 1500hr	More than 1000hr
Tubing endurance *3	More than 750hr (Pharmed BPT)	
Operating external temperature	0°C to 50°C (No condensation, No freezing)	
Operating humidity	20% to 85% (No condensation)	
Standard	UL/CE/RoHS Compliant	CE/RoHS Compliant

Note:

- *1 The tubing on the discharge side may rupture if blocked, resulting in a potentially dangerous situation. Be sure to design the discharge side such that the pressure is less than the discharge pressure.
- *2 Measurement conditions for the pump noise level conform to JIS B 8310: 1985.
- *3 The values indicated for durable service life are not guaranteed. The data shown is the result of tests performed by flowing distilled water under the conditions of 20°C room temperature, and intermittent switched operation of 60 seconds ON and 15 seconds OFF. The results vary depending on the chemicals used, ambient temperature and humidity, and operating cycle conditions. Use the indicated values as guidelines.

Motor wiring terminal dimensions diagrams

12 or 24VDC Brush Motor

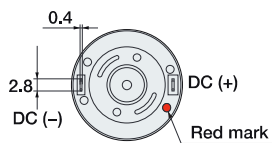

12VDC Compact Brush Motor

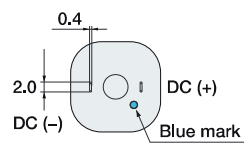

Dimensions (unit:mm)

WPM - AA - P

WPM - BA - P

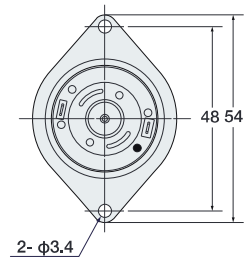
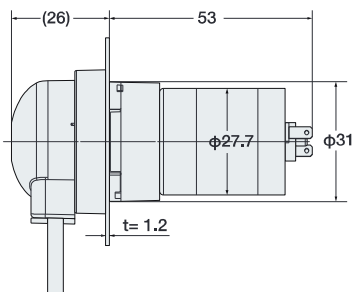
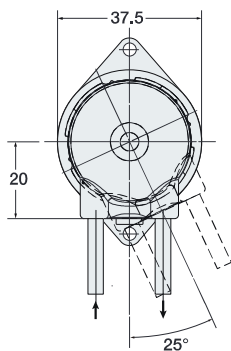

Weight: 83g

WPM - AB - P

WPM - BB - P

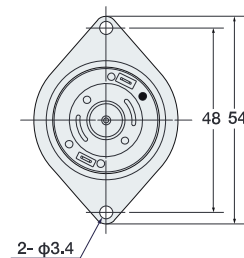
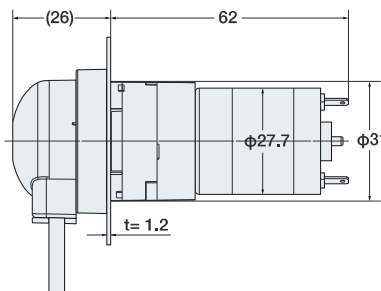
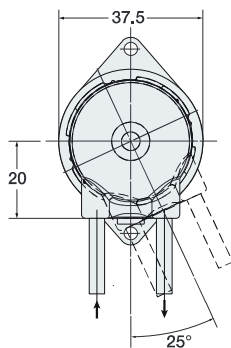

Weight: 90g

WPM - CA - P

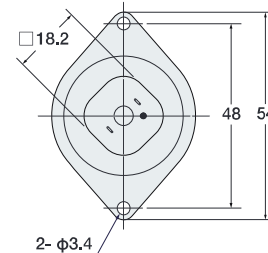
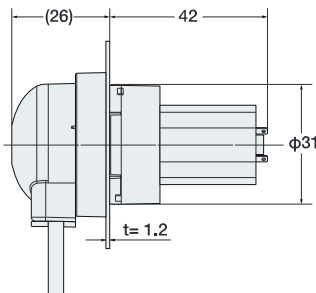
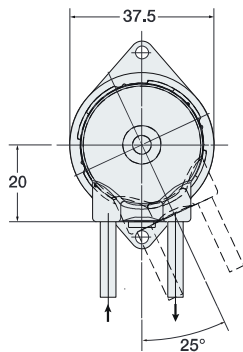

Weight: 67g

Cutting hole dimensions
Using screws

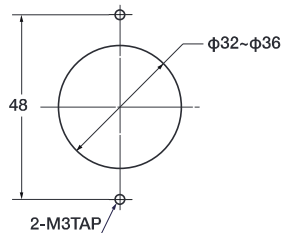

Cutting hole dimensions
One-touch mounting

Panel thickness: 1.0 to 1.2

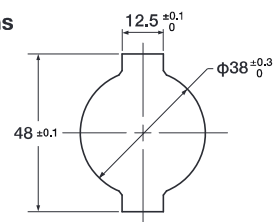



Stepper Motor & Gear

Specification

Geared motor model	EA type
Configuration	Hybrid stepper motor & 1:14 Gear ratio
Number of phases and motor type	2 phase/BI polar system
Rated Voltage	4.48V
Rated Current	0.56A/Phase
Step Angle	0.0643° (Half step)/0.0323° (1/4 micro step)
RPM	1 to 150rpm
Duty Ratio	Max. 50%
Winding Resistance	8.0Ω±10%
Inductance	7.1mH
Motor Insulation Class	B
Motor operating temperature	less than 80°C(176°F)
Life	5,000hr (Geared motor) *Not a guaranteed value.

Motor wiring terminal dimensions diagrams

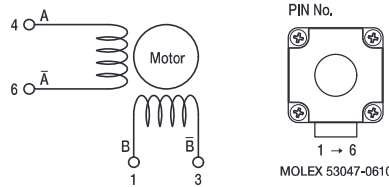

Dimensions (unit: mm)

WPM□ - □□EA-□-□P

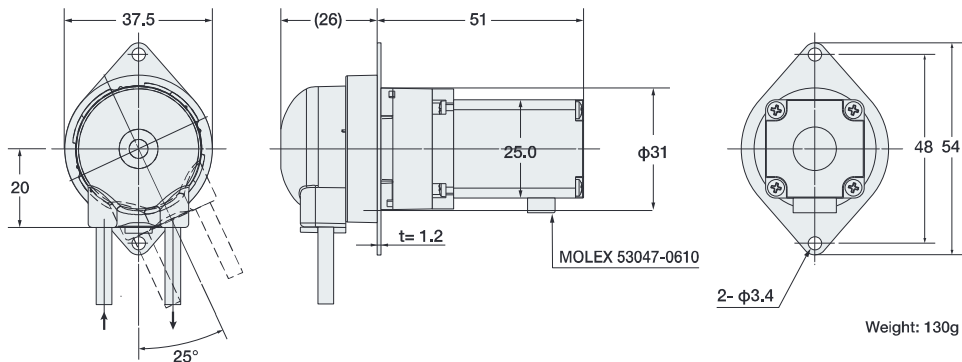

Cutting hole dimensions Using screws

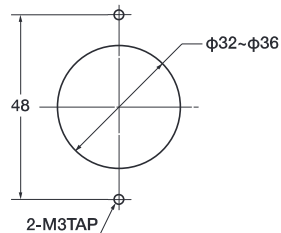

Cutting hole dimensions One-touch mounting

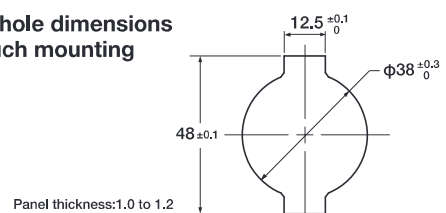



Brushless Motor & Gear

Specification

Geared motor model	DB type	FB type
Configuration	Brushless motor & 1:196 Gear head	
Operation Voltage *1	DC12V (DC9V to DC12V)	DC24V (DC15V to DC24V)
Current *2	Less than 200mA	
Pump Rev.	Approx. 20 to 28rpm	Approx. 25 to 43rpm
Rotatory direction	CW	
Motor operating temperature	less than 70°C	
	This motor is equipped with an IC inside its casing. When the drive IC reaches a predefined temperature, the motor power shuts down automatically. There is no guarantee that a power motor having been shutdown due to temperature will be reusable.	
Motor lock protection	2sec TYP	
	If the motor locks up, the motor power will shut down within a predefined time. The motor will restart upon power-up.	
Life	5,000hr (Geared motor) *Not a guaranteed value.	

*1.The lowest operation voltage may vary depending on the tube type, tube size, ambient temperature, etc. Please contact your sales representative to get help when you operate by lower voltage.
*2.Caution: The consumption current described above is the value during normal operations. An approximately threefold inrush current occurs during rotation startup.

Motor wiring terminal dimensions diagrams

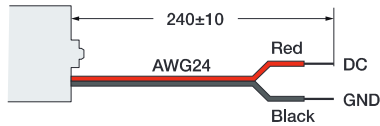

Circuit protection

This motor is not equipped with a circuit for protection against overvoltage and connection to terminals at the incorrect polarity. Be careful not to apply surge voltages that exceed the rated voltage and not to connect to the incorrect polarity.

Dimensions (unit:mm)

WPM□ - □□DB-□-□P WPM□ - □□FB-□-□P

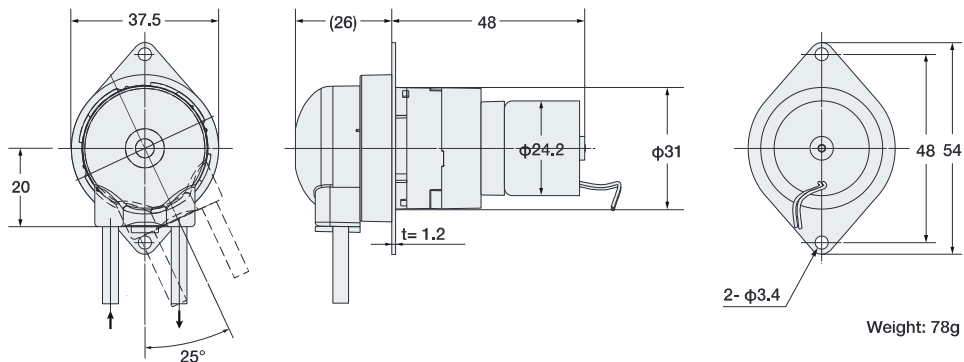

Cutting hole dimensions Using screws

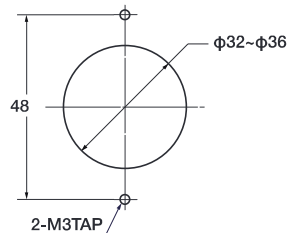

Cutting hole dimensions One-touch mounting

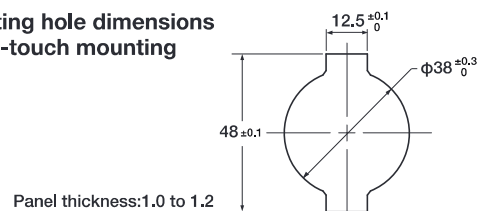

5 Color variation

A 10-color lineup that can be classified for use according to the type of liquids used

WPM1 - P 3 AA - W
↑



W : White



B : Blue



Y : Yellow



O : Orange



R : Red



G : Green



C : Clear (WPM2)



NB : New/Blue



NY : New/Yellow



NR : New/Red



NG : New/Green

6 Using an optional panel

WPM1 - P 3 AA - W P
↑

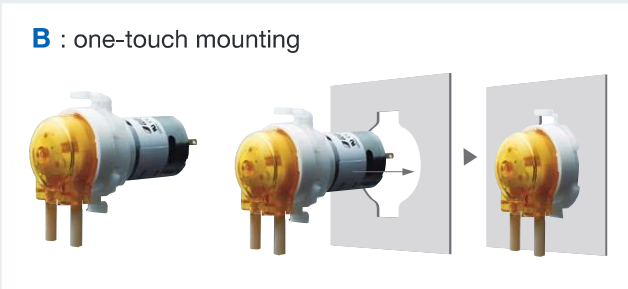

General specification

Model name	WPM1	WPM2
Recommended installation height	2 meter (6.8 ft.) max (Water suction)	
Liquid temperature range	5-50°C (32 to 122°F)	5-80°C (32 to 176°F)
Environment temperature range	0-50°C (32 to 122°F) (Note: Freezing must be prevented.)	
Ambient humidity range	20-80% RH (Note: Condensation must be prevented.)	
Max. Discharge pressure *1	90kPa (Pharmed BPT) Silicone 80kPa or less	
Max. Suction pressure *1	-90kPa (Pharmed BPT) Silicone -80kPa or less	
Autoclave	Not Available	Autoclave condition: 0.1MPa, 121°C, 20min Only the Pump parts. *2
Material (Pump parts)	PSU (Cassette/Rotor/Base) POM (Roller,etc)	PSU (All parts)
Certifications & Approvals	 E209254 *Except CA type	

Note: *1 The tubing on the discharge side may rupture if blocked, resulting in a potentially dangerous situation.

Be sure to design the discharge side such that the pressure is less than the discharge pressure.

*2 Autoclave sterilization is assumed to be performed under the conditions of 0.1 MPa (121°C) for 20 minutes.

Number of autoclave is supposed less than 30 times. (except pump tube)

If the actual conditions will exceed these values, be sure to perform a confirmatory evaluation. Even when using tubing that can be autoclaved, performing the autoclave sterilization process while the tubing is fitted to the pump may cause the flow rate to change. If this is a concern, remove the tubing and sterilize.



PeriPump GmbH | Badenerstrasse 816 | CH-8048 Zürich
Tel: +41 43 811 75 02 | contact@peripump.eu | www.peripump.eu

Precautions

- When selecting a tube, the customer should perform a verification test to verify the chemical suitability according to the usage environment and the intended application.
- Regardless of the pump tube type, the phenomenon of peeling from inside of the tube starts with small amounts.
- This product was not designed for medical use. Do not use for medical applications.
- This product is not waterproof. If using in water-filled environments, design to protect against water.
- Numerical data listed in this catalog reflect conditions measured over short periods of time. Their accuracy for long-term use is not assured.
- There is a tendency for the flow rate to increase until the tube becomes acclimated, and even among the same model, different lots may have different flow rates within the specified tolerances. Also, the rotating speed of the DC motor may fluctuate depending on the load conditions and changes in the motor temperature. During the design stage, be sure to select a motor with ample capacity.
- Product pictures may be shown with slightly different colors than the actual products.
- Product specifications and appearance are subject to change without notice.



WELCO Co., Ltd.

3-3-1 Sumiyoshi-cho, Fuchu-shi, Tokyo 183-0034, Japan Tel: +81-(0)42-333-7320 Fax: +81-(0)42-333-7337

Please see the web site to get more detailed information. <http://www.welco.net>

welco

SEARCH 